

Light Emitting Diode Lamp

★ Package Dimensions

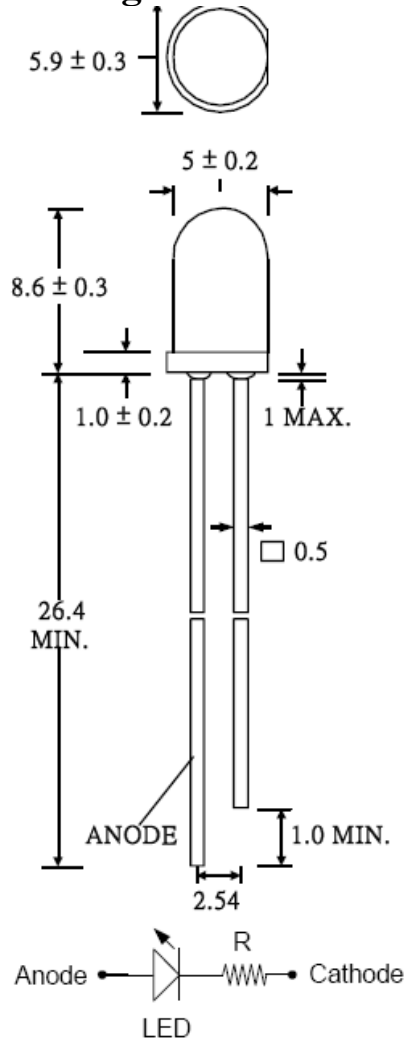

NOTE:

1. All dimensions are in millimeter.
2. Lead spacing is measured where the lead emerge from the package.

★ Selection Guide

Part NO.	Chip		Lens Color	Viewing Angle Θ 1/2(deg)
	Material	Emitted Color		
5-22-CD36-10/5V	GaAlAs	Super Red	Red diffused	50

Light Emitting Diode Lamp

Part No: 5-22-CD36-10/5V

★Absolute Maximum Ratings (Ta=25°C)

Parameter	Symbol	MAX. Rating	Unit
Power Dissipation	Pd	125	mW
Peak forward current (10 μs Pulse)	IFP	50	mA
Reverse Voltage	VR	5.0	V
Operating Temperature	Topr	-40~+85	°C
Storage Temperature	Tstg	-40~+85	°C
Lead Soldering Temperature (1.6mm From Case Bottom 260°C For 5 SEC)			

★Electric-Optical Characteristics

Parameter	Symbol	Test Condition	MIN	TYP	MAX	Unit
Forward Voltage	VF	IF=20mA		5		V
Reverse Voltage	IR	VR=5V			10	uA
Luminous Intensity	IV	IF=20mA	330	500		mcd
Peak Emission Wavelength	λ P	IF=20mA		660		nm
Spectrum Width Of Half Value	Δ λ	IF=20mA		25		nm

★Characteristics Diagrams

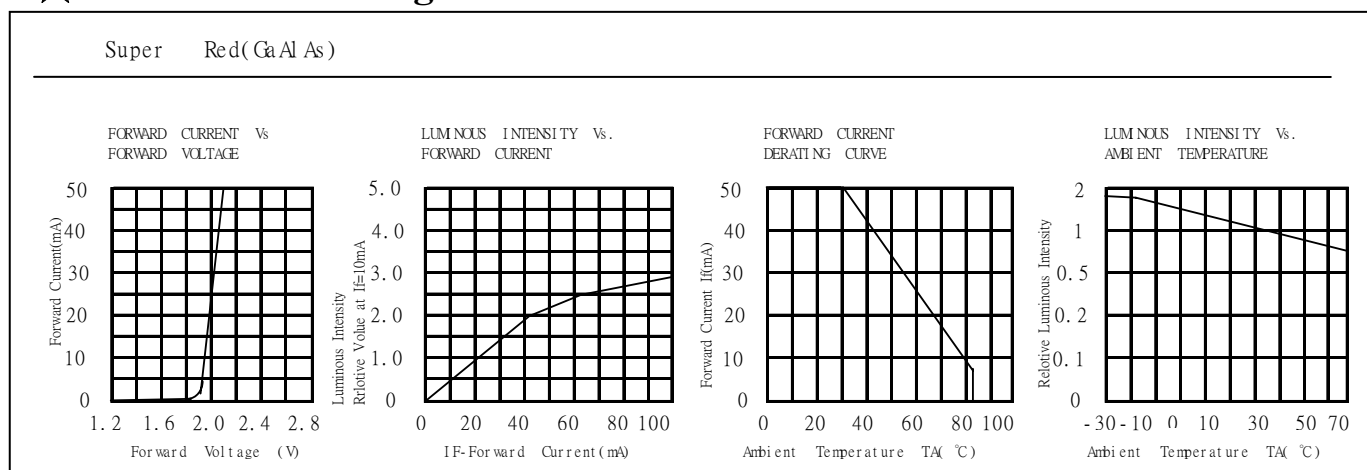

Light Emitting Diode Lamp**Part No: 5-22-CD36-10/5V****★Reliability Test**

No	Item	Test Condition	Test Hours/Cycles	Samples Tested	Acc./Rej
1	Room Temperature DC Oper-ating Life	Ta=25°C, I _F =20mA	1000 Hrs	76	0/1
2	Thermal Shock	-10°C (5min)→ (10sec)→+100°C (5min)	100 Cycles	76	0/1
3	Temperature Cycle	-40°C (30min) →(5min)→+85 °C (30min)	100 Cycles	76	0/1
4	High Temp./ High Humi. Test	85°C/85%RH	1000 Hrs	76	0/1
5	High Temperature Storage	Ta=100°C	1000 Hrs	76	0/1
6	Low Temperature Storage	Ta= - 40°C	1000 Hrs	76	0/1
7	Soldering Heat	260°C±5°C	5 Seconds	76	0/1