



Housing: Die-Cast Aluminum, Painted Black  
 Blade: Thermoplastic PBT, UL 94V-0  
 Insulation Resistance: 100M $\Omega$ , 500VDC/min between bare wire and frame  
 Dielectric Strength: 1500VAC for one minute  
 Operation Temperature: -10°C-70°C(Humidity 35%-85%RH)  
 Storage Temperature: -40°C-85°C(Humidity 35%-85%RH)  
 Motor Protection: Impedance Protected  
 Weight: 320 g

**AC AXIAL FAN**  
**110x110x25mm**



SS

IP

Model Number	Voltage (VAC)	Frequency (Hz)	AirFlow (CFM)	Stat.Pres. (mm-H <sub>2</sub> O)	Noise (dBA)	Speed (RPM)	Current (mA)	Power (W)	Available Bearing	Curves
FA1125B11T5-96	115	50/60	43.6/49.7	4.1/4.6	36.4/39.4	2,000/2,200	130/110	12/10	8,5	①/②
FA1125B11T7-96	115	50/60	48.7/55.8	4.6/5.2	38.4/41.4	2,100/2,300	140/120	13/11	8,5	③/④
FA1125B22T5-96	230	50/60	43.6/49.7	4.1/4.6	36.4/39.4	2,000/2,200	80/70	11/9	8,5	①/②
FA1125B22T7-96	230	50/60	48.7/55.8	4.6/5.2	38.4/41.4	2,100/2,300	90/80	12/10	8,5	③/④

- For "Sleeve" bearing version, change the "B" in the model number to "S".
- For "Wire Lead" version, change the "T" in the model number to "W".

Specifications are subject to change without notice

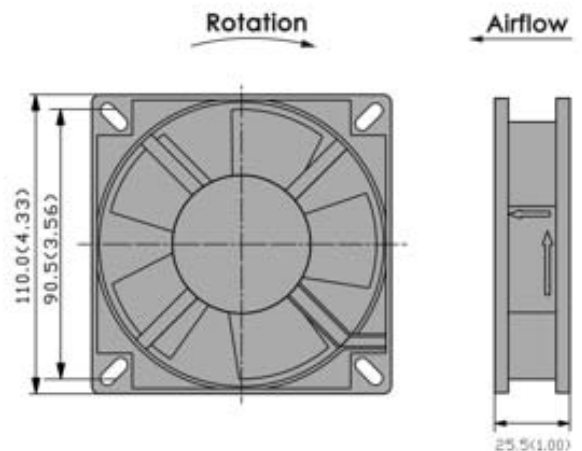
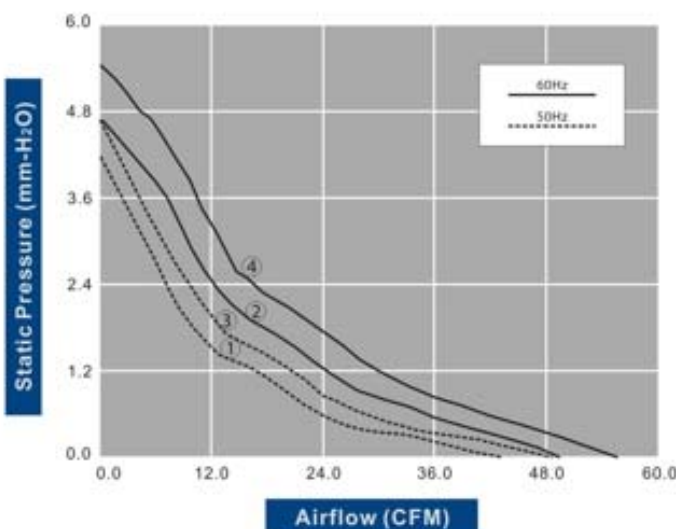

unit: mm(inch)