



Housing: Die-Cast Aluminum, Painted Black  
 Blade: Injection Molded of Flame Retardant Polycarbonate, Black  
 Insulation Resistance: 100M $\Omega$ , 500VDC/min between bare wire and frame  
 Dielectric Strength: 1500VAC for one minutue  
 Operation Temperature: -20°C-70°C(Humidity 35%-85%RH)  
 Storage Temperature: -40°C-85°C(Humidity 35%-85%RH)  
 Motor Protection: Thermal Protected  
 Weight: 1000 g

**AC AXIAL FAN**  
**170x150x55mm**



Model Number	Voltage (VAC)	Frequency (Hz)	AirFlow (CFM)	Stat.Pres. (mm-H <sub>2</sub> O)	Noise (dBA)	Speed (RPM)	Current (mA)	Power (W)	Available Bearing	Curves
FA1755B11W7C-51	115	50/60	204.0/235.0	14.7/18.9	57.0/61.0	2,900/3,400	340/380	38/44	B	①/②
FA1755B22W7C-51	230	50/60	202.0/239.0	14.7/18.9	57.0/61.0	2,900/3,400	170/190	37/43	B	①/②

Specifications are subject to change without notice

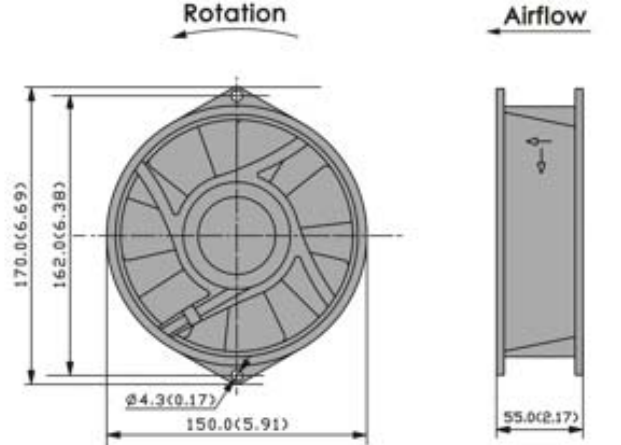
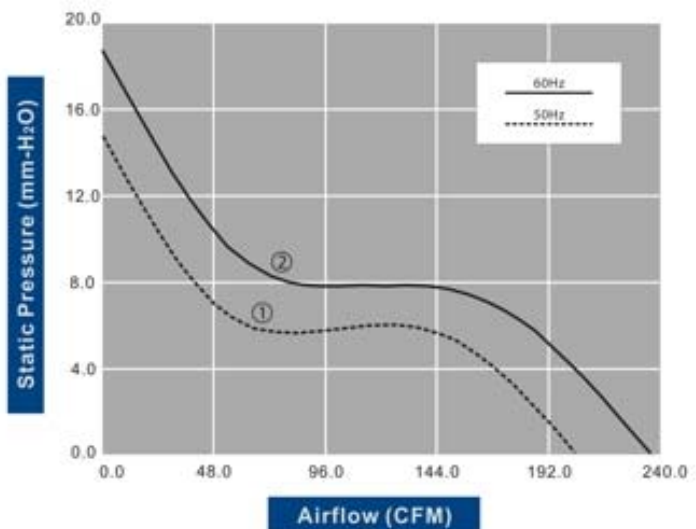

unit: mm(inch)