

1 2 3 4 5 6 7 8 9 10

A  
B  
C  
D  
E  
F  
G  
H  
I  
J

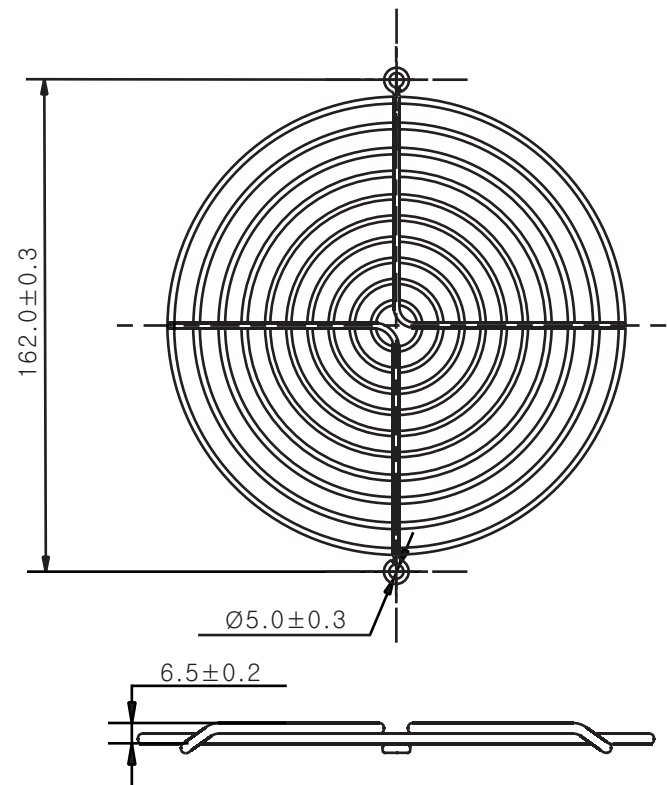

Fits for Fan Size:

172x150x38mm; 172x150x51mm

Ø172x51mm; 172x151x55mm

Specifications:

- \* Materials: Bright basic wire.
- \* Finish: bright nickel chrome plating.
- \* (1) Rings are Ø1.8mm
- \* (2) Ribs are Ø1.8mm
- \* Weld joints to withstand 220 lbs pull force.
- \* Part meets Ø6.35mm plug gauge test.
- \* Flat with Thru-hole style.

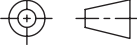
TITLE		PART DRAWING		REV	CHANGES	BY/DATE	APPD/DATE
PART NAME		WIRE FORM FAN GUARD		<b>COOLTRON INDUSTRIAL SUPPLY, INC.</b> 			
PART NO.		FGW-162B-1					
MODEL NO.				LINEAR (0.50) ±0.10 ±0.05 (50,100] ±0.20 ±0.10 (100,+∞) ±0.30 ±0.15		ANGLUAR X. ±0.5° X.X ±0.1°	
APPD.	DATE			PROJECTION: 		UNIT	MM
CHECK	DATE			MATERIAL		SCALE	
DRAWING	TONY	DATE	8/10/2007	FINISH		DWG NO.	REV