



RF SERIES

Radial Type, Through-Hole

RF series capacitors are ideal for use in switching power supplies.
Other High Frequency Applications.
Low Impedance and long life.

Characteristics

Voltage Range	6.3 to 100 VDC				160 to 450 VDC				
Capacitance Range	4.7 to 15000uF				1 to 470uF				
Temperature Range	-40 to +105°C				-25 to +105°C				
Leakage Current	I ≤ 0.01CV or 2uA, whichever is greater 3 minutes after Rated Voltage applied				I ≤ 0.03CV or 3uA, whichever is greater 3 minutes after Rated Voltage applied				
Capacitance Tolerance	±20% at 120Hz, 20°C (10% Tol. is available upon request)								
Dissipation Factor	Working Voltage (V)	6.3	10	16	25	35	50	63	100
	tanδ(%) max	22	19	16	14	12	10	9	8
	Working Voltage (V)	160	200	250	350	400	450		
	tanδ(%) max	12	12	12	15	15	17		
Low temperature Characteristics (120Hz)	For capacitance > 1000uF, add 0.02 for every 1000uF.(at 20°C, 120Hz)								
	Working Voltage (V)	6.3	10	16	25	35	50	63	100
	Z-25°C/Z 20°C	4	3	3	3	3	3	2	2
	Z-40°C/Z 20°C	8	6	4	3	3	3	3	3
	Working Voltage (V)	160	200	250	350	400	450		
	Z-25°C /Z 20°C	2	2	3	5	5	6		
Z-40°C /Z 20°C	3	6	6	6	6	-			
For capacitance > 1000uF, add 0.5 every 1000uF for -25°C /+20°C add 1.0 every 1000uF for -40°C /+20°C									
Load life :	After the rated voltage with ripple current has been applied for at 105°C		Capacitance change		Within ±20% of initial value				
D φ	Life Hours		D.F. tanδ		200% or less of initial specified value				
5 - 6.3 φ	2000		Leakage current		Less than initial specified value				
8 φ	3000		(160V ~ 450V : 2000HRS)						
≥10 φ	5000								
Shelf life (at 105!)	After 1000 hrs no load: test the leakage current, capacitance and tan δ are same as load life value.								

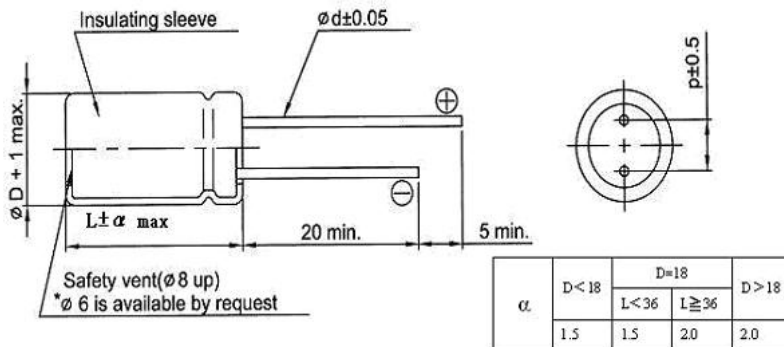

Drawing

Dφ	5	6.3	8	10	13	16	18
p	2.0	2.5	3.5	5.0	5.0	7.5	7.5
dφ	0.5	0.5	0.5	0.6	0.6	0.8	0.8

Ripple Current Coefficients

Frequency (Hz)	60	120	400	1K	10K	50K - 100K
Cap.(uF) / Hz	Multiplier					
Cap. ≤ 10	0.47	0.59	0.76	0.85	0.97	1
10 < Cap. ≤ 100	0.52	0.62	0.80	0.89	0.97	1
100 < Cap. ≤ 1000	0.58	0.72	0.84	0.90	0.98	1
1000 < Cap.	0.63	0.78	0.87	0.91	0.98	1



RF SERIES

Radial Type, Through-Hole

WV (SV)	400 (450)			450 (500)		
	Spec. DφxL(mm)	Impedance (Ω)max 20°C 100KHZ	Ripple Current mA(rms) 105°C 100KHz	DφxL(mm)	Impedance (Ω)max 20°C 100KHZ	Ripple Current mA(rms) 105°C 100KHz
uF						
1	8x12	16.5	36	8x12	17.35	41
2.2	10x12.5	13.0	76	10x16	10.25	65
3.3	10x12.5	12.0	105	10x16	10.00	89
4.7	10x21	10.0	120	13x21	5.01	105
10	13x21	3.32	235	13x26	3.78	180
22	13x26	2.65	295	13x26	2.80	320
33	16x26	1.60	440	16x26	2.20	460
47	16x31.5	1.40	580	16x36	1.02	650
68	18x32	0.80	800	18x36	0.78	760
100	18x41	0.60	900			

ORDERING INFORMATION for Leaded Type



Daewoo Components Corp.

Through-Hole Part Numbering System Example:

RM = Leaded Radial 85°C Miniature Series, **102** = 1000µF, **M** =20% Tolerance, **1E** 25 Volts, **B** = Bulk,
1020 = Case size (Dia x H) = 10.0 x 20.0mm, **E** = 5.0mm

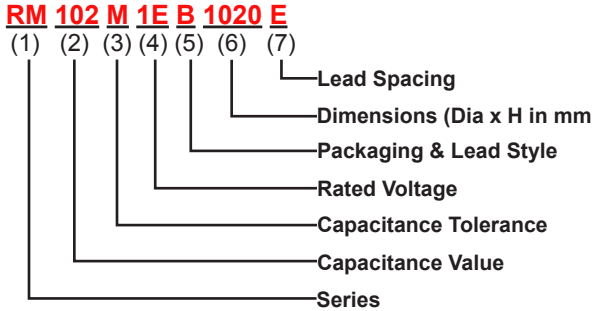

(1) Series

See Quick Guide on page 2
Example: RSS, RM, RMU,...

(2) Capacitance Value Code

Capacitance expressed in micro Farads (µF)
First two digits are significant figures
Third digit denotes the number of zeros
Use R for decimal point for values less than 10µF

Examples:

CODE	Capacitance
R10	0.1 µF
R68	0.68 µF
1R0	1.0 µF
100	10 µF
680	68 µF
471	470 µF
102	1000 µF
103	10000 µF

(3) Capacitance Tolerance Code

CODE	Cap. Tol.	CODE	Cap. Tol.
J	±5%	V	-10% ~ +20%
K	±10%	Q	-10% ~ +30%
M	±20%	T	-10% ~ +50%
R	+20%, -0%		

(4) Rated Voltage Code

CODE	Voltage	CODE	Voltage
0G	4.0V	2C	160V
0J	6.3V	2S	180V
1A	10V	2D	200V
1C	16V	2E	250V
1E	25V	2F	315V
1V	35V	2V	350V
1H	50V	2G	400V
1J	63V	2W	450V
1K	80V	3Z	1000V
2A	100V		

(5) Packaging Form & Lead Style Code (see page 7, 8, 9 for details)

	Code	Packaging Form & Lead Style
Bulk	B	Bulk: Standard Package
	L	Bulk: 4 -8ø Long Leads Formed to 5 mm Pitch
Snap-In	1	10-13ø Snap-in Cut 5.0mm
	2	16-13ø Snap-in Cut 5.0mm
	3	10-13ø Snap-in Cut 4.5mm
	4	16-18ø Snap-in Cut 4.5mm
	5	4-8ø Snap-in Cut 7.5mm
Form	F	4-8ø Forming Cut 6.5mm
	G	4-8ø Forming Cut 10.0mm
Straight Cut	C	4-18ø Straight Cut 4.0mm
	6	4-18ø Straight Cut 3.1mm
	7	4-18ø Straight Cut 5.0mm
	8	4-18ø Straight Cut 6.35mm
Ammo Tape (+) Leading	A	4-8ø Straight Ammo Detail Ranges: 4-6.3ø; F=2.5mm 8ø; F=3.5mm
		4-8ø Form Tape & Ammo 5mm Pitch
		10ø Straight Ammo Tape 5mm Pitch
		13ø Straight Ammo Tape 5mm Pitch
		16-18ø Straight Ammo Tape 5mm Pitch
Tape & Reel (+) Leading	T	4-8ø Straight Ammo Detail Ranges: 4-6.3ø; F=2.5mm 8ø; F=3.5mm
		4-13ø Form Tape & Reel 5mm Pitch
		10-13ø Straight Reel Tape 5mm Pitch

NOTE: Standard Pack Anode(+) Lead Leading FEEDS OFF FIRST
Special Option Cathode(-) Lead Leading available upon request
Standard Packages: B = Bulk, A = Ammo, T = Tape & Reel

(6) Example Dimension Code (Diameter x Height in mm)

Size Code	Diameter	Height	Size Code	Diameter	Height
0405	4	5	1320	13	20
0407	4	7	1631	16	31.5
0505	5	5	1835	18	35.5
0507	5	7	2240	22	40
0607	6.3	7	2545	25	45
0511	5	11	3035	30	35
0605	6	5	3500	35	100
0611	6.3	11	3501	35	110
0805	8	5	5102	51	120
0811	8	11	6303	63.5	130
1012	10	12.5	7604	76	140
1220	12.5	20	8904	89	140

(7) Lead Spacing Code (LS)

Code	X	A	B	C	D	E	J	F
LS	1.0	1.5	2.0	2.5	3.5	5.0	7.0	7.5
Code	K	M	G	P	H	Q	R	S
LS	8.0	10.0	10.5	12.0	12.5	12.8	15.0	16.0
Code	T	U	V	W	Y	Z		
LS	20.0	21.7	28.3	30.0	31.6	32		